

BUOY SHACKLES – A TYPE & B TYPE

Nominal Diameter for Chain	A	B	C		D		E	F	G	H	Mass	
	A & B Type	A & B Type	A Type	B Type	A Type	B Type	A & B Type	A & B Type	A & B Type	B Type	A Type	B Type
mm	mm	mm	mm		mm		mm	mm	mm	mm	kg	
38	225	113	395	375	42	60	53	80	150	188	28	26
40	234	118	406	384	44	62	56	83	150	188	31	30
42	243	125	416	394	46	63	59	85	150	188	35	34
44	254	130	427	401	48	66	62	88	150	188	41	39
46	264	136	438	410	51	69	64	90	150	188	46	45
48	275	141	458	429	53	72	67	92	160	200	52	51
50	288	148	470	440	55	75	70	95	160	200	59	57
52	299	153	490	460	57	78	73	98	170	213	67	64
54	313	161	504	472	59	81	76	101	170	213	74	72
56	321	165	524	491	62	84	78	104	180	225	83	80
58	334	172	538	503	64	87	81	108	180	225	93	89
60	345	177	549	513	66	90	84	111	180	225	102	99
62	358	184	561	525	68	93	87	115	180	225	113	109
64	369	189	594	556	70	96	90	119	200	250	123	119
66	379	195	606	566	73	99	92	122	200	250	136	131
68	390	200	617	576	75	102	95	125	200	250	148	143
70	403	207	628	586	77	105	98	127	200	250	161	154
73	421	215	645	601	80	109	102	132	200	250	182	175
76	435	223	663	615	84	113	106	137	200	250	205	197
78	448	230	675	625	86	116	109	140	200	250	222	213
81	468	242	697	641	89	119	114	146	200	250	250	239
84	483	251	716	655	93	122	119	152	200	250	279	268
87	497	259	735	670	96	127	123	158	200	250	311	298
90	513	267	753	684	99	130	127	164	200	250	345	332

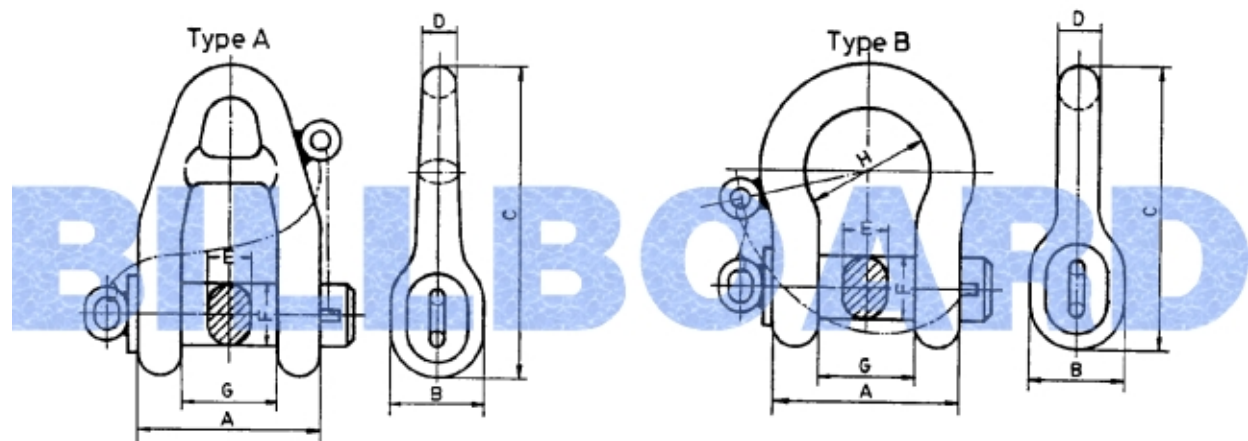

DEVIL'S CLAW Chain Stopper

- assist in securing the anchor at the hawse pipe
- be utilized to help retrieve mooring components

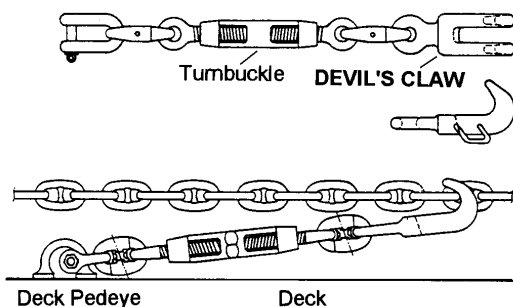

PELICAN HOOK Chain Stopper

- to secure the ship's anchor at hawse pipe
- be disengaged from the stopper by manually deflecting the bail

